



GENUINE PARTS

INSTALLATION INSTRUCTIONS

DESCRIPTION:	Accent Lighting Kit
APPLICATION:	Altima
PART NUMBER(S)	999F3 U4500
REQUIRED FOR INSTALLATION:	999Q9 AY000 (Accessory Service Connector) - Not Included in Accent Lighting Kit
KIT CONTENTS:	

Item	Qty.	Part Description	Service Part Number
A	1	Control Module	998F3 U4505
B	1	Footwell Lights and Harness Assembly	999F3 U4501
C	1	Bin Light	998F3 U4502
D	1	Cup Holder Lights and Harness Assembly	998F3 U4506
E	1	2-Button Color Selection Switch and harness	998F3 U4504
F	1	Vehicle Interface Harness	998F3 4RA7A
G	1	Hardware Kit	998F3 U4503
H	1	Quick Reference Card	
I	1	Installation Instruction Replacement Template	999V2 AW000

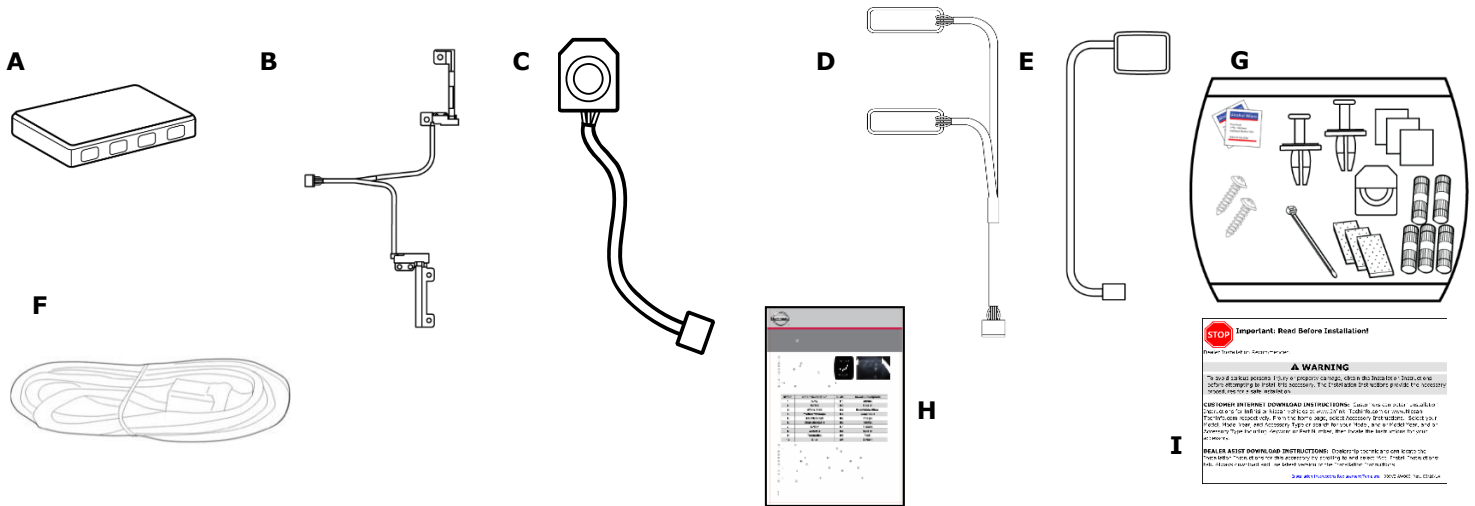

999Q9 AY000 (ACCESSORY SERVICE CONNECTOR) - SERVICE PART

Item	Qty.	Part Description	Service Part Number
AA	1	Accessory Service Connector (NOT INCLUDED IN KIT)	999Q9-AY000



Note: 1 or 2 ASC may already be installed in the vehicle.

TOOLS REQUIRED:

- Trim Stick (Nylon)
- #2 Phillips Screw Driver
- Side Cut Pliers
- (Awl) Center Hole Punch
- LED & Switch Location Templates
- 90 Degree Small Drill
- 1/8" , 3/8" , & 7/16" pilot point drill bits
- Step Drill
- Electrical Tape
- DeBurring Tool

PRE-INSTALLATION CAUTION/NOTES

- Dealer installation recommended. Instructions may refer to Service Manual
- Installation may require special tools
- This part is to be installed within a surface temperature range of 65-100°F

CAUTION

- This accessory must only be installed as specified in these instructions.
- Ensure at all times that parts are securely fitted and will not compromise the safe function of vehicle systems

Vehicle Preparation:

⚠ CAUTION

- Always confirm the ignition is in the "OFF" position before changing the switch condition.

- 1) Apply parking brake
- 2) Confirm vehicle is not in the default shipping state or "Inventory position" as shown below. Failure to confirm vehicle has been removed from this state will result in loss of normal vehicle operation.
- 3) Locate Extended Storage Switch in cabin fuse block. Confirm it is in the "Customer" position. See below for reference.

- a) To remove transit mode (Fuse Block):
1. Remove fuse cover lid.
 2. Push down shorting pin.
 3. Ign On 2 times without starting the vehicle.

- b) To remove transit mode (BCM):
1. Confirm ignition switch is in "OFF" position.
 2. Simultaneously push the signal and wiper switch fully down for two (2) seconds.

NOTE: While in BCM Transit Mode, turn signal indicators will remain illuminated for one minute.

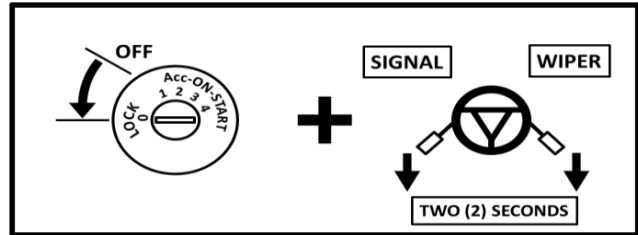
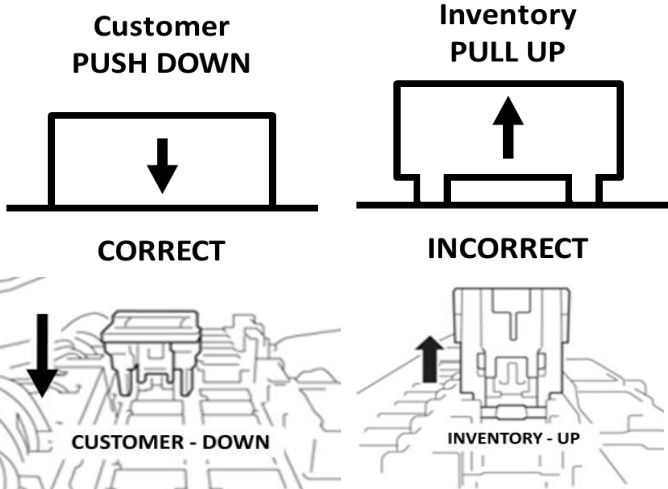

- c) To return to transit mode for storage:
1. Ign Off.
 2. Remove fuse cover lid.
 3. Pull up shorting pin.
 4. Assemble fuse cover lid.
 5. Ign On 2 times without turn the vehicle on.
 6. Confirm transit mode condition on meter

NOTE: Typical vehicle condition shown above. Switch is easily identifiable by the permanent, push-pull fuse holder. Actual position on the fuse block may vary, vehicle to vehicle.

Condition	Switch Position	Note
Vehicle is delivered to the dealer	Inventory Condition	
Technician performs PDI	Customer Delivery	Return to Inventory position after PDI.
Customer test drives the vehicle	Customer Delivery	Return to Inventory position after test drive.
Vehicle is being stored at the dealer	Inventory Condition	
Vehicle is delivered to customer	Customer Delivery	

NOTE: The Extended Storage Switch is only an aid to improve battery life during vehicle storage at the dealer. If the Extended Storage Switch fuse ever needs service after vehicle delivery, discard the Extended Storage Switch and install the correct fuse in its place.

- 4) Turn ignition switch to "ON" position
- 5) Record the customer radio presets and other presets as required.

Preset	1	2	3	4	5	6		

- 6) Put shift lever in "P" position for A/T and CVT or "1st" for M/T
- 7) Turn ignition switch to "OFF" position
- 8) Use seat and floor protection.

INSTALLATION PROCEDURE:

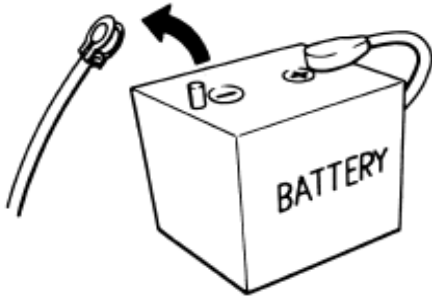

- 1) Turn ignition switch to "**OFF**" position
- 2) Disconnect the negative battery terminal.
 - a) Lower both the driver and passenger windows to prevent damage.
 - b) Disconnect the negative battery terminal.

Order of Installation

- a. Interior preparation - remove panels.
- b. Install - Passenger Footwell light.
- c. Install - Driver Footwell light.
- d. Install - Vehicle interface.
- e. Install - Cup Holder light
- f. Install Bin Light
- g. Install ECU
- h. Reinstall - Panels.
- i. System check.

INSTALLATION OVERVIEW (Normal):

System Block Diagram

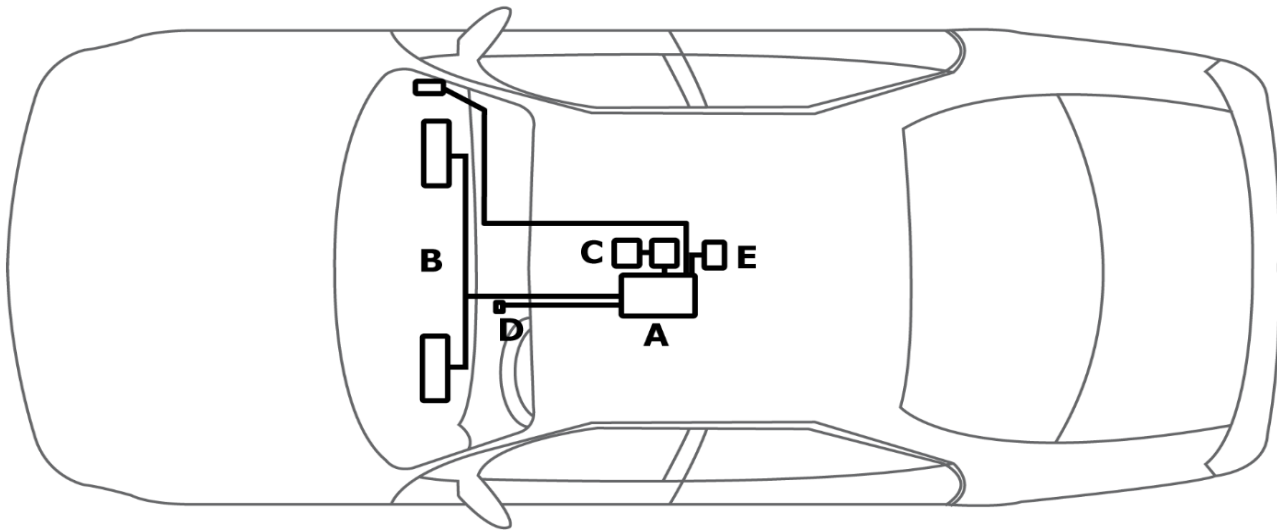
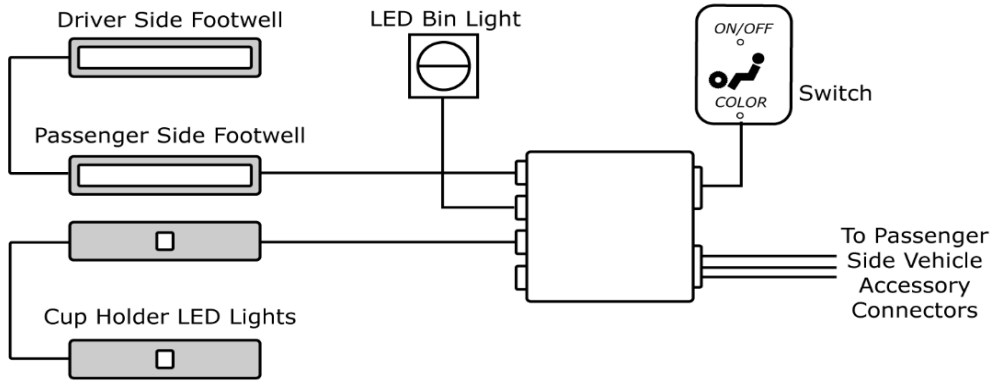

- A) Controller Module
- B) Foot Well Lights
- C) Cup Holder Lights
- D) Switch
- E) Bin Light

CRITICAL STEPS:

The following steps are critical and must be performed **EXACTLY** as specified to ensure proper installation:

- **Location of the lights must be followed exactly as described in this instruction.**
- **Posi-Tap™ instructions must be specifically followed as described.**

INSTALLATION PROCEDURE:

Fig. 1

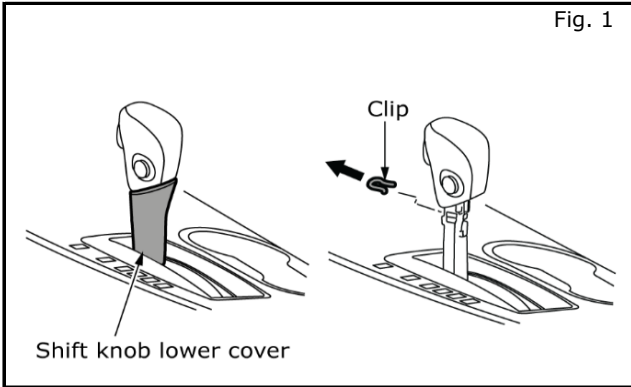

- 1) Remove gear selector knob.
 - a) With shift lever in neutral position, use nylon pry tool to release finisher ring at bottom of shift knob and push boot down.
 - b) Remove retaining clip holding shifter knob to selector lever.
 - c) Lift shift knob upward to remove and reinstall clip with bend upward. Set shift knob aside.

Fig. 2

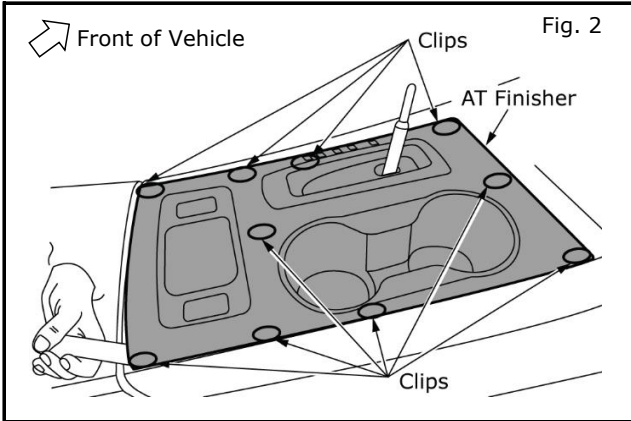

- 2) Remove center stack finisher and bin.
 - a) Begin at rear of finisher (in front of and to passenger side) using nylon pry tool to release clips.
 - b) Lift finisher upward, holding at both rear corners to release clips without twisting.
 - c) When all side clips are released, pull finisher toward rear of console to remove.
 - d) Pull rear bin out of console after finisher is removed. Some have heater switches (see Note below).

Fig. 3

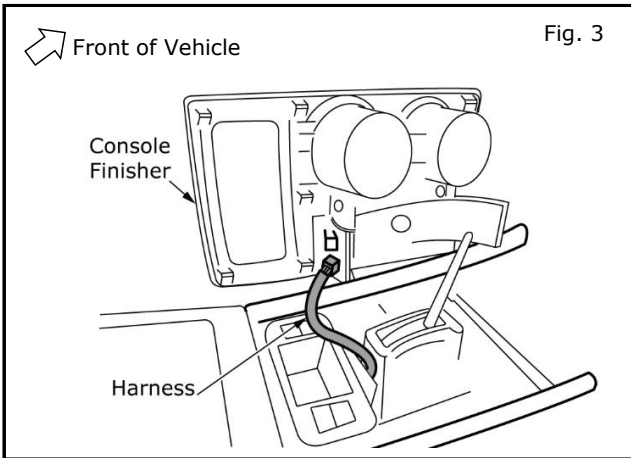

- e) Disconnect connectors and set finisher aside on soft work surface.

Fig. 4

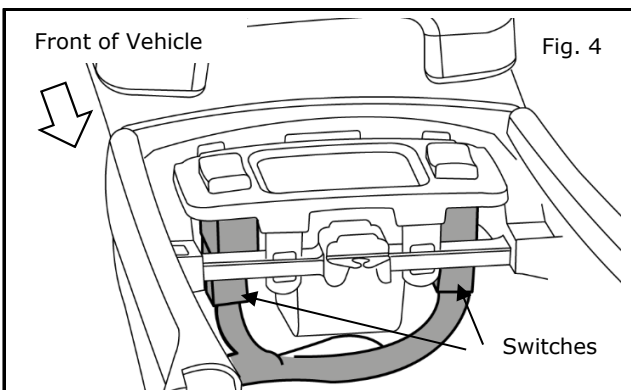

NOTE:

Sequence disconnecting connectors if seat heater switches are installed.

- 1) **Disconnect Grey connector first.**
- 2) **Disconnect Brown connector second.**
- 3) **Reconnect in reverse order**

INSTALLATION PROCEDURE:

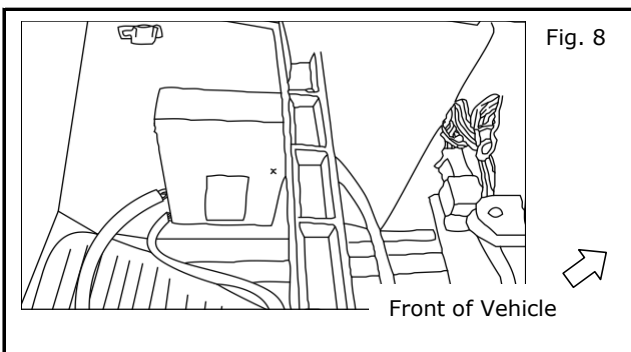
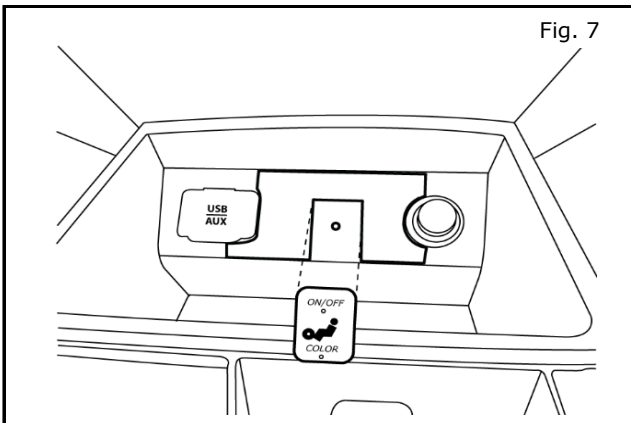
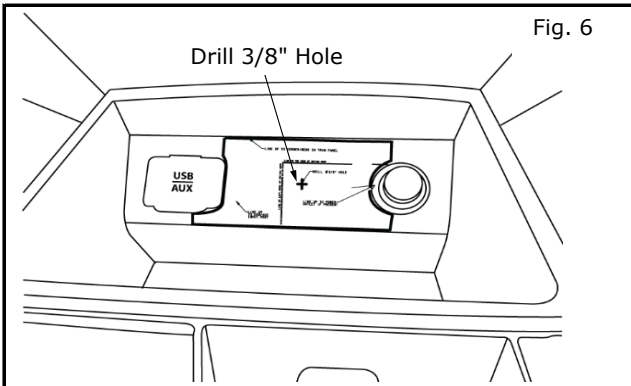
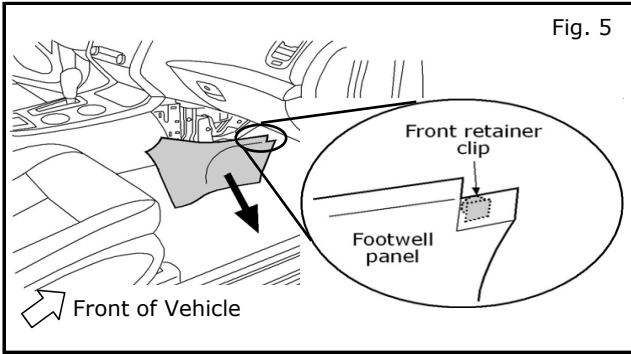

- 3) Remove side trim.
 - a) Carefully pry out center footwell panel from passenger side of center console.
 - b) Pull out at center and slide to rear.

NOTE:

Ensure front retainer clip stays with panel.

- 4) Drilling hole for switch in front bin as shown using the supplied drilling template.
 - a) Measure and mark hole using awl.
 - b) Drill 3/8" hole.
 - c) Deburr hole and clear debris.
 - d) Clean with Alcohol wipe before installing switch.

- 5) Install switch.
 - a) Use mounting template as guide to install switch
 - b) Peel adhesive backing from switch.
 - c) Insert harness connector in hole and route harness
 - d) through hole.
 - e) Align top of switch parallel to recess line.
 - f) Contact switch adhesive to console.
 - g) Press firmly and hold. Apply 15 lbs. pressure for 20 seconds.
 - h) Route harness under front bin and through console to rear where control module will be mounted

- 6) Locate position ECU on left inner side of console, just behind cross brace as pictured.

NOTE:

Do not adhere module to center console at this time. Step is just for location reference. Adhere module after all connectors are installed.

- 7) Remove Passenger side door sill and front kick panel

INSTALLATION PROCEDURE:

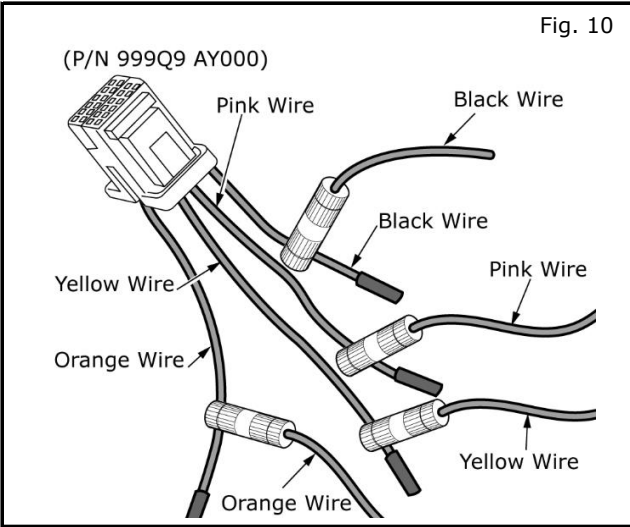
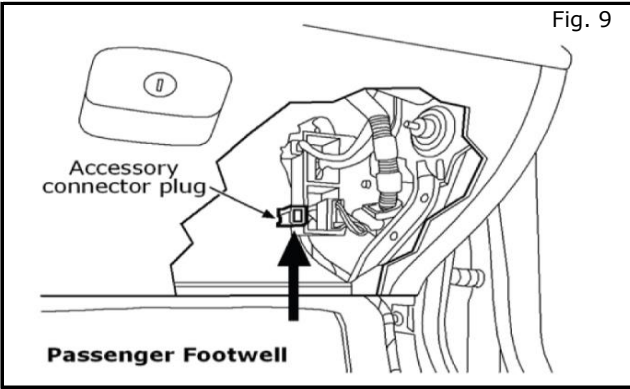

Fig. 11

999Q9 AY000		
Pin	Label	Color
1	BAT	RED
2	N/A	N/A
3	ACC	ORANGE
4	N/A	N/A
5	BAT_SVR	PINK
6	DOOR_SW	GRN
7	THRU_SIGNAL 1	DK BLUE
8	THRU_SIGNAL 2	LT BLUE
9	N/A	N/A
10	RM LMP	YELLOW
11	N/A	N/A
12	GND	BLACK

7	8	10	12
1	3	5	6

BAT

Pin location is referenced looking into face of connector.

- 8) Locate passenger side D-Opt connector located next to glove box on right side A-Pillar.

NOTE:

A previously installed accessory may be present. If so, carefully remove accessory connector harness from D-Opt connector before posi-tapping. It is recommended that all posi-tapping be completed before reattaching accessory connector harness to plug.

- 9) Connect lighting power harness to accessory connector harness using posi-taps.
- Connect **BLACK** wire from power harness to **BLACK (GND)** wire on accessory connector harness.
 - Connect **ORANGE** wire from power harness to **ORANGE (ACC)** wire on accessory connector harness.
 - Connect **PINK** wire from power harness to **PINK (BATT_SAVER)** wire on accessory connector harness.
 - Connect **YELLOW** wire from power harness to **YELLOW (ROOM_LAMP)** wire on accessory connector harness.
 - Tape back **BROWN** wire from power harness to power harness - **not used**
- 10) Accessory service connector pin out reference is shown in Fig. 11.

INSTALLATION PROCEDURE:

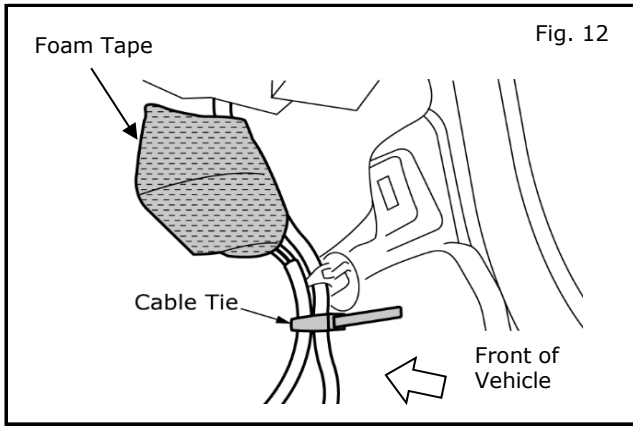

- 11) Connecting accessory connector to service connector.
 - a) Tape Posi Taps with as shown on page 10-12, wrap posi tap bundle with foam tape as shown.
 - b) Connect accessory connector to service connector.
 - c) Tie stap harness to existing harness as shown.

Note:

- See Pages 10 - 12 for posi-tap instructions.
- Accessory connector harness (P/N 999Q AY000) NOT INCLUDED in kit.

INSTALLATION PROCEDURE: POSI-TAP

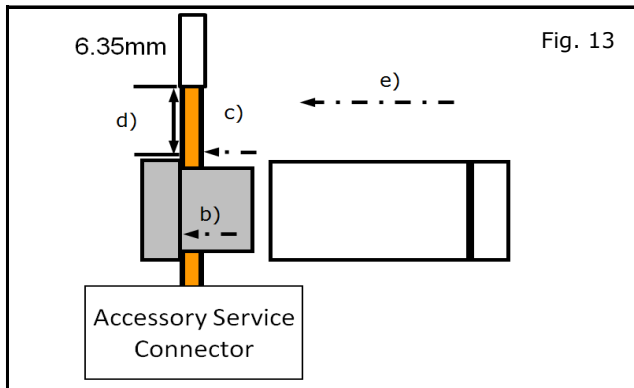

- 12) Posi-tapping an Accessory service wire (Fig. 13)
 - a) Identify and confirm correct wire in the Accessory Service Connector to be tapped.
 - b) Remove cap (slot side) from tap body.
 - c) Slide cap around single accessory wire.
 - d) Position cap $\geq 6.35\text{mm}$ (0.25in) away from the heat shrink end of Accessory Service Connector (measurement for first posi-tap installed on the circuit).
 - e) Tighten the tap **TIGHT** with finger pressure.
 - f) Tighten by another quarter turn.

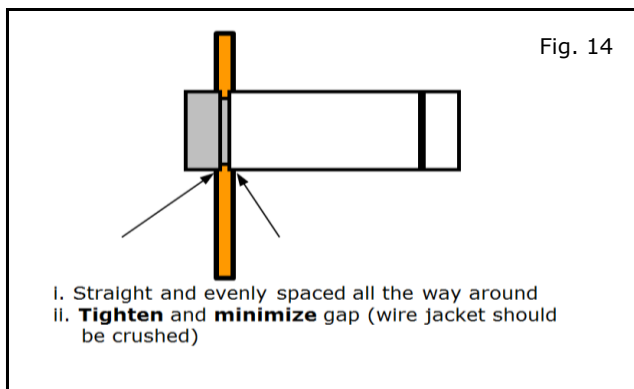

- 13) Inspecting the tap for correct installation (Fig. 14).
 - a) Pull on the wire lightly to ensure connection.
 - b) Inspect the tap to ensure correct installation.
 - c) Test the signal to ensure that it is working properly.

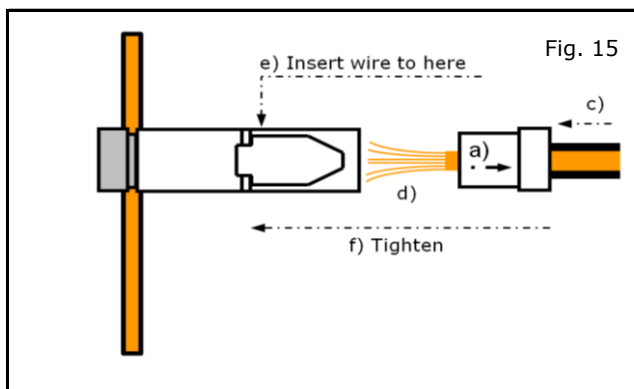

- 14) Tap accessory wire (Fig. 15).
 - a) Remove tap (non-pierce) side from tap.
 - b) Remove the protective stub from the wire.
 - c) Insert wire through the non-pierce side opening.
 - d) Spread the individual strands into fan shape.
 - e) Insert wire into the tap body and ensure that it is all the way in.
 - f) Tighten the tap **TIGHT** with finger pressure.
 - g) Tighten by another quarter turn.

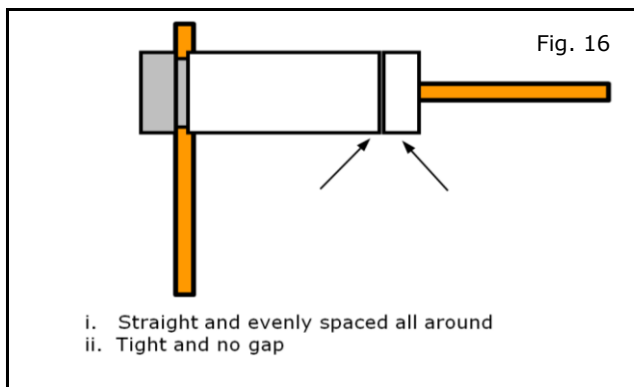

- 15) Confirm the tapped accessory wire.
 - a) Pull on the wire lightly to ensure connection.
 - b) Inspect the tap to ensure correct installation as shown in Fig. 16.

INSTALLATION PROCEDURE: POSI-TAP

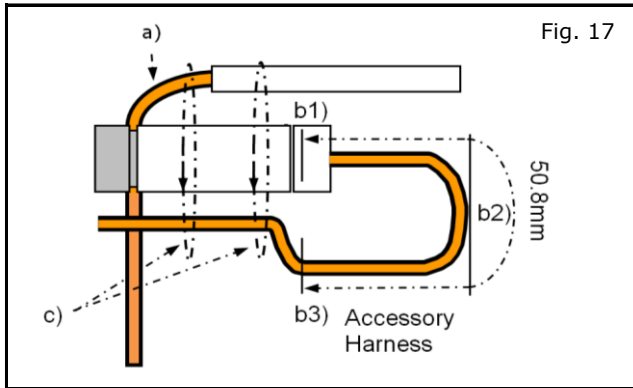

- 16) Forming strain relief loop - required (Fig. 17).
- Gently bend end of pierced wire (where it exits cap) down towards body of posi-tap.
 - On tapped side wire; starting at point b1), measure 50mm to point b3). Make first bend of loop b2), half measured distance - 25mm, and up toward body of posi-tap, make second bend of loop b3).
 - Secure pierced wire on heat shrink side and tapped wire to body of tap with electrical tape (≥ 2 revolutions).

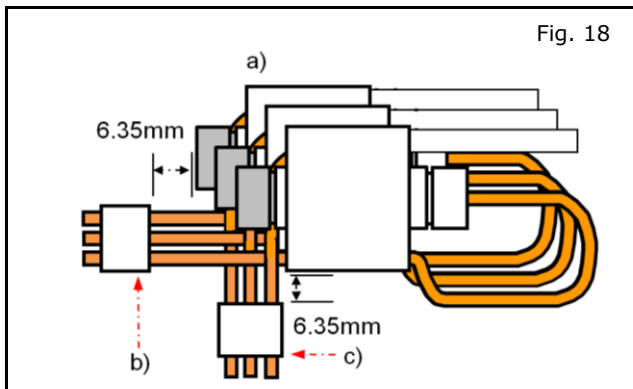

- 17) Securing multiple accessory taps (Fig. 18).
- Tapped accessories (wires already secured to tap bodies) are stacked in a stagger on top of each other as shown in Fig a).
 - Secure tapped wires on connector side of posi-taps to each other with electrical tape (≥ 2 revolutions) at a distance of ≥ 6.35 mm as shown in Fig b).
 - Pierced wires of posi-taps are secured to each other with electrical tape (≥ 2 revolutions) at a distance of ≥ 6.35 mm (0.25in) as shown in Fig c).

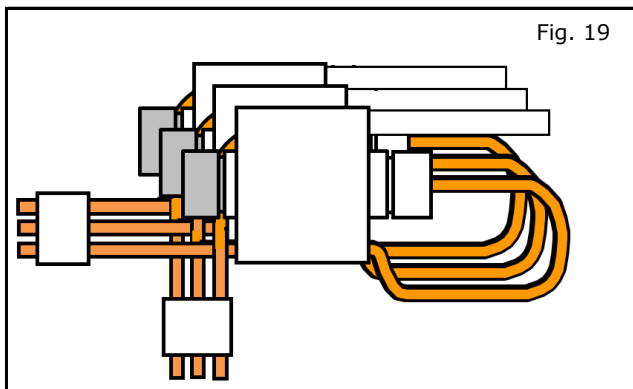

- 18) Securing multiple accessory taps (Fig. 19).
- Make sure the accessory taps have been wrapped appropriately as detailed previously and as shown.

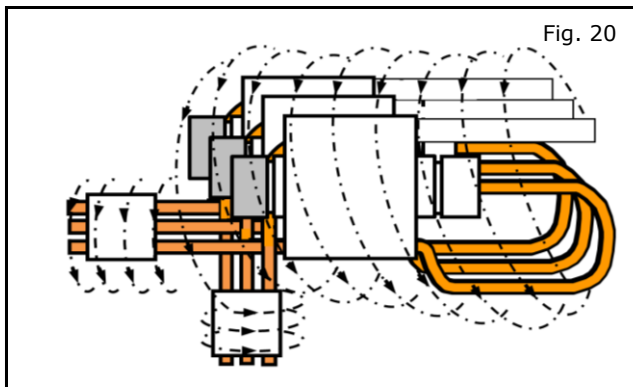

- 19) Securing multiple accessory taps
- Starting at heat shrink; firmly wrap posi-tap bundle with electrical tape or non-adhesive wire harness tape, making sure to overlap previous revolution.
- Note:** If using non adhesive tape secure at the of wrap with electrical tape ≥ 2 revolutions.

INSTALLATION PROCEDURE: POSI-TAP

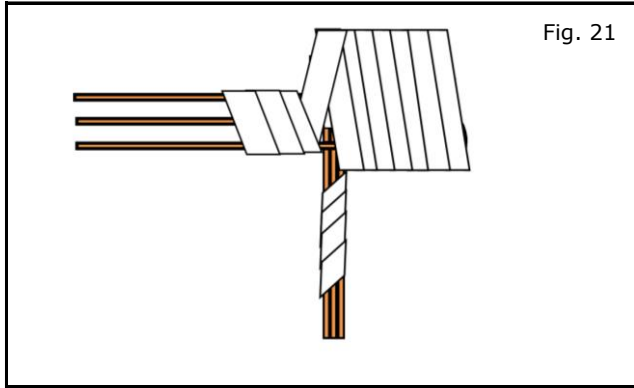

- 20) Securing multiple accessory taps
a) Make sure the finished wrap looks similar to Fig. 21.

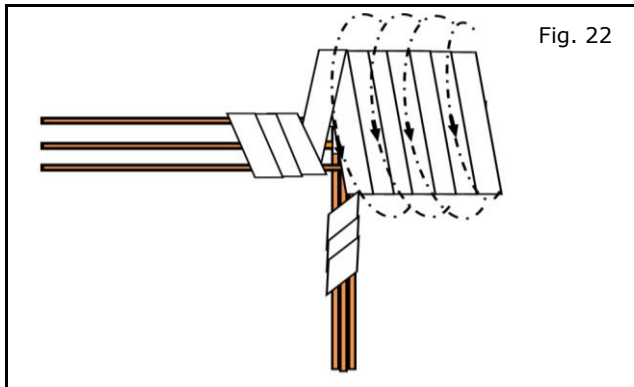

- 21) Foam wrap for posi-tap bundle (foam strips)
a) Wrap the posi-tap bundle with foam tape, following a pattern similar to the electrical tape, making the best use of foam strips provided.

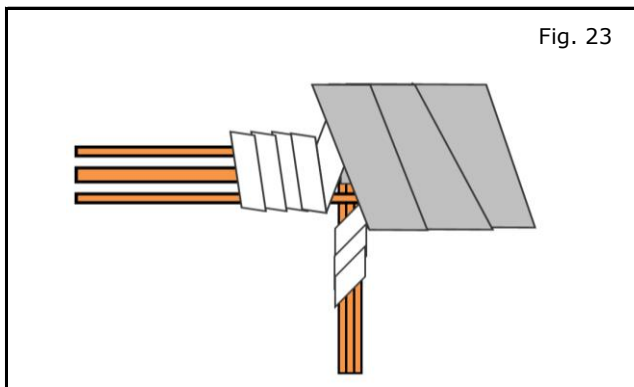

- 22) Finished foam wrap for bundle (strips-top view)
a) Make sure the finished wrap looks similar to Fig. 23.

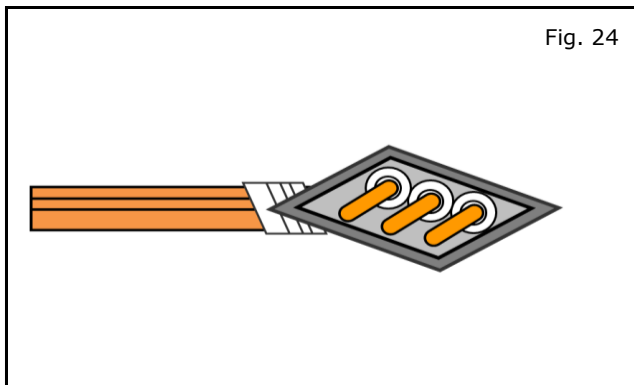

- 23) Finished foam wrap for bundle (strips-side view)
a) Make sure the finished wrap looks similar to what is shown in Fig. 24.

INSTALLATION PROCEDURE:

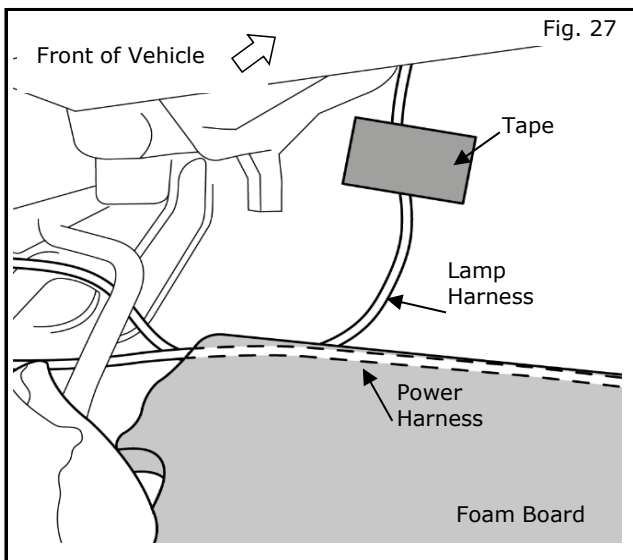
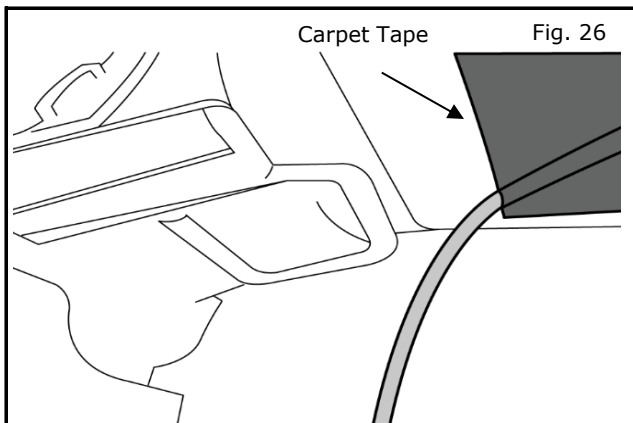
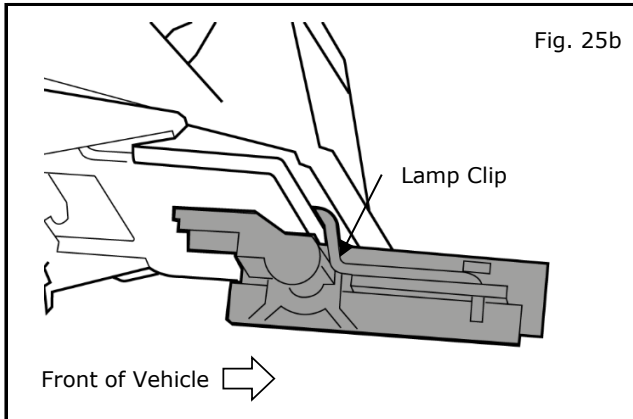
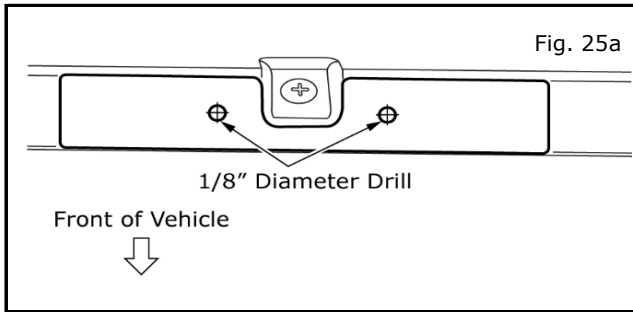

- 24) Attach passenger side lamp to bottom of glove box using drill template.
- Using template, drill 1/8" pilot hole. Use stop on drill to go no more than 1/2" deep.
 - Carefully slide clip between finisher panel and securely attach lamp to molded boss with two (2) M5x16M screws supplied in kit.
 - Route harness back behind glove box and secure lamp harness to glove box using 1 piece of carpet tape (provided in kit) to keep harness from sagging and close to carpet.
- 25) Route interface harness.
- Route power harness and lamp harness under carpet and foam insulation as shown.
 - Using supplied tape secure in one place as shown.

INSTALLATION PROCEDURE:

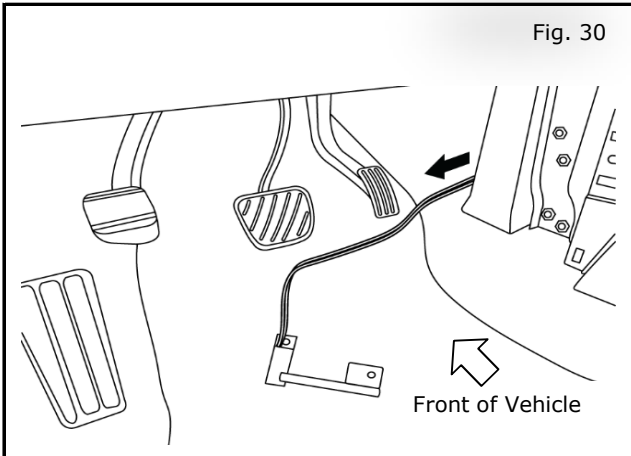
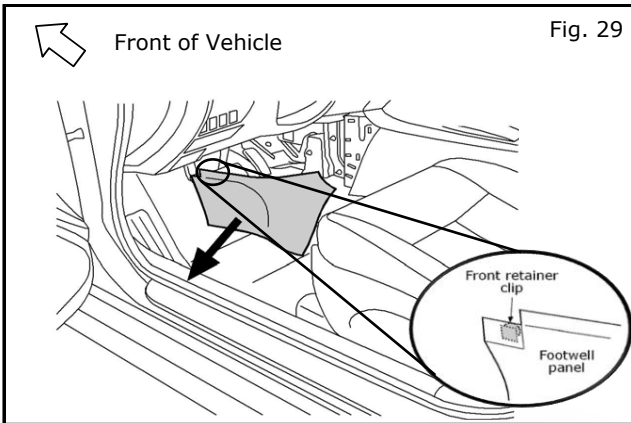
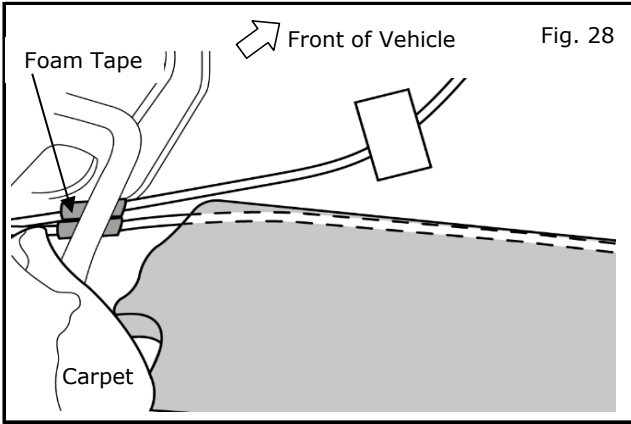

- c) Add foam tape where harness goes into center stack
- d) Check that harness route is not exposed or can be snagged.

- 26) Carefully pry out center footwell panel from driver side of center console.
 - a) Pull out at center and slide to rear.

NOTE:

Remove center footwell panel. Ensure front retainer clip stays with side panel.

- 27) Pass driver side lamp from right footwell area to left footwell area.

INSTALLATION PROCEDURE:

Fig. 31

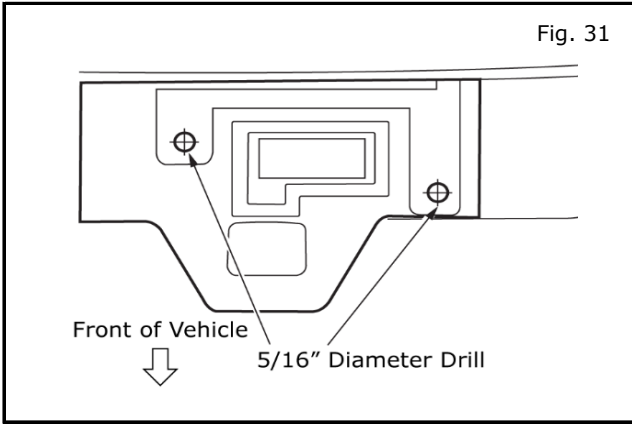

- 28) Mount lamp on driver lower instrument panel.
 - a) Tape mounting area to protect panel.
 - b) Using template, mark and drill 1/8" pilot hole.
 - c) Finish hole with 5/16" (8mm) drill bit and deburr.
 - d) Remove tape cover before attaching light to panel.
 - e) Use two push-pin fasteners supplied in kit to secure lamp to panel.

NOTE: Tape drill to control depth to 1/2 inch

Fig. 32

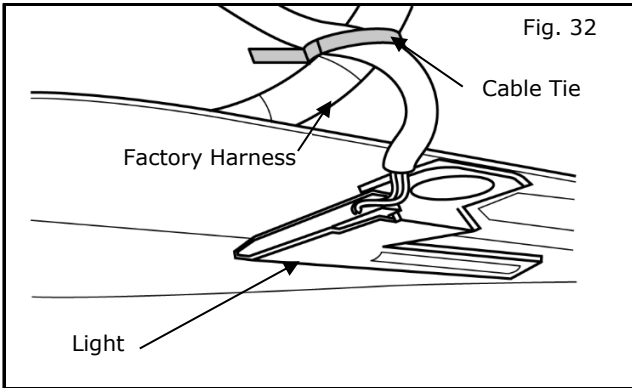

- 29) Routing driver side lamp wire.
 - a) Cable tie accent light harness directly above interior light as shown.

- b) From factory harness, route accent light harness over drain tube.

NOTE: Do not tie strap the LED harness to the drain tube.

Fig. 33

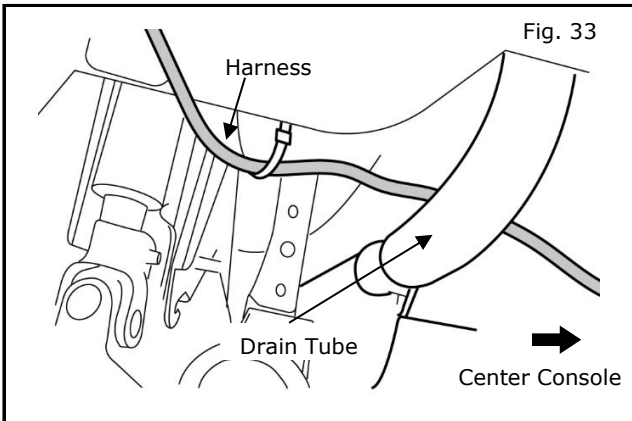

- c) Cable tie accent light harness to factory bracket on side of center console.

Fig. 34

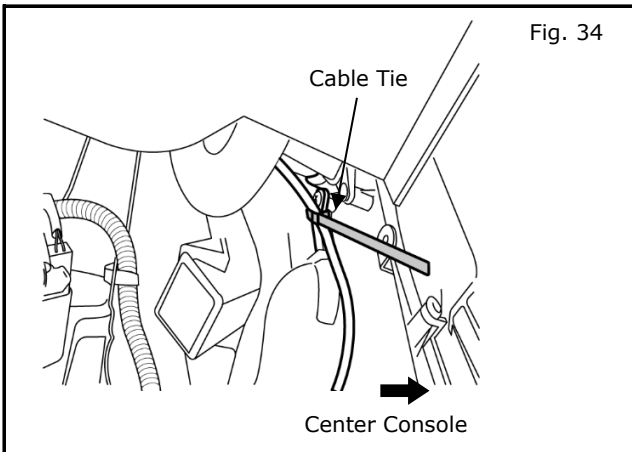

INSTALLATION PROCEDURE:

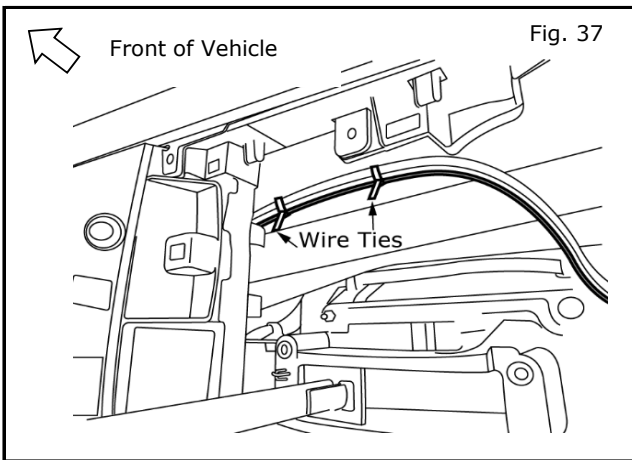
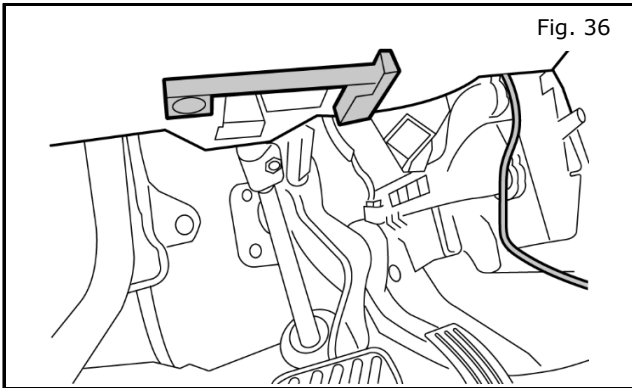
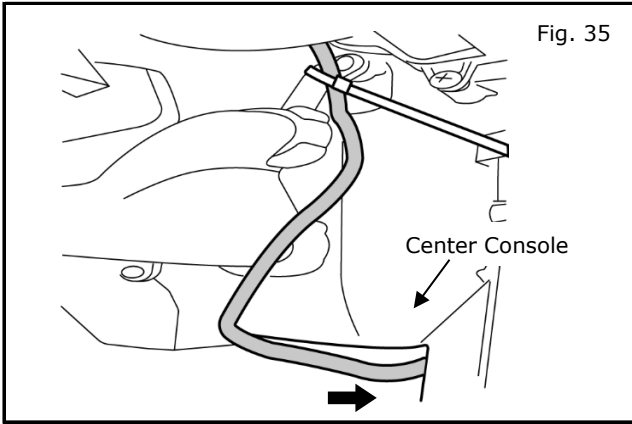

d) Route harness under center console.

NOTE:

Ensure harness is secured and no slack can be caught by steering shaft or pedals

- 30) Routing harnesses in console
- a) Route power harness, footwell light and switch harnesses through console toward module, tie strap (2) to main harness as shown.
 - b) Reinstall the drivers and passengers side center console panels.

INSTALLATION PROCEDURE:

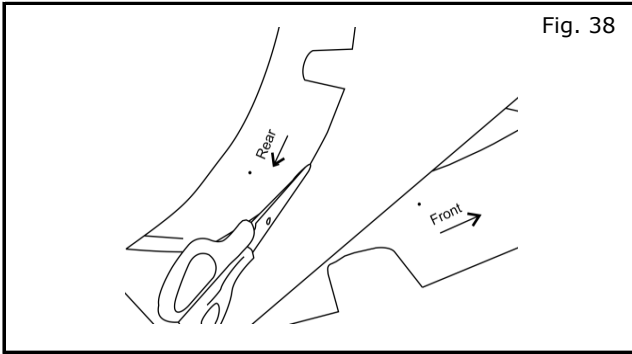

- 31) Cup holder light mounting
 - a) Print paper templates for drill hole locations.
 - b) Measure 1" scale box to confirm size.
 - c) If scale box is too large, reduce image %.
 - d) Use scissors to cut out each template.
 - e) Cut line at each end to form slit.

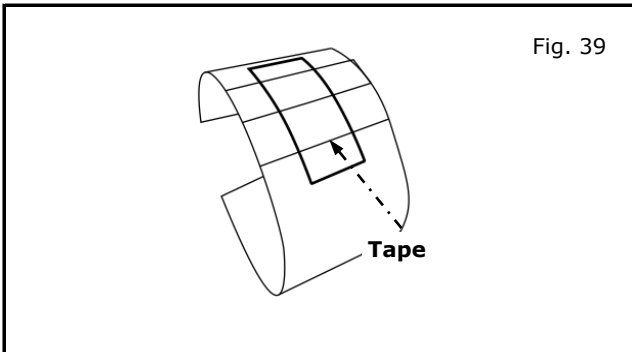

- 32) Mark hole location template collar.
 - a) Engage slits and tape flat to make collar.

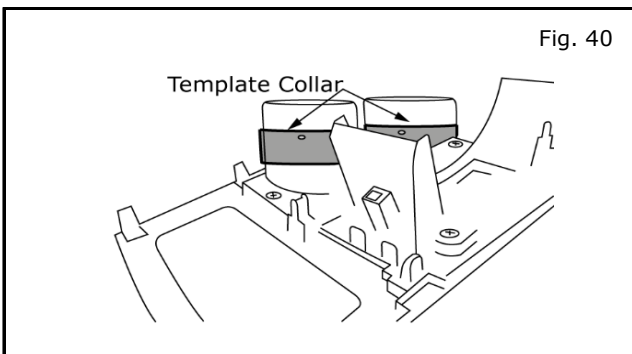

- 33) Align hole location template collars.
 - a) Align front template collar with front cup holder and place in position as shown.
 - b) Align rear template collar with rear cup holder and place in position as shown.

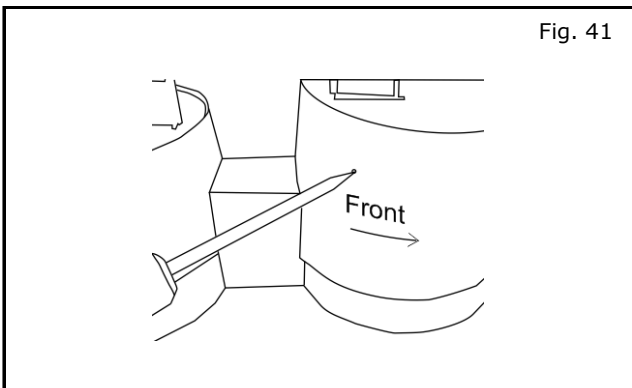

- 34) Mark front and rear hole locations.
 - a) Use an awl or center punch to mark each hole location.

INSTALLATION PROCEDURE:

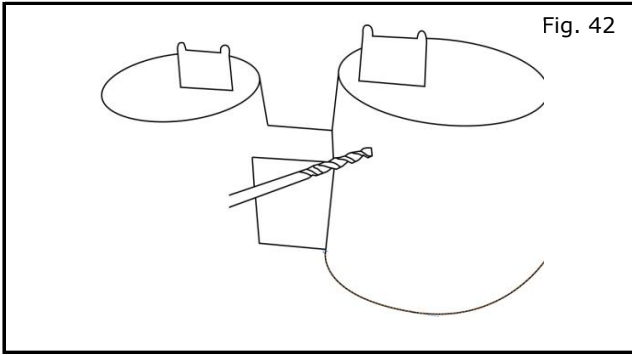

- 35) Mark and drill pilot hole.
- Remove paper template collars.
 - Drill a 1/8" pilot hole for each location.

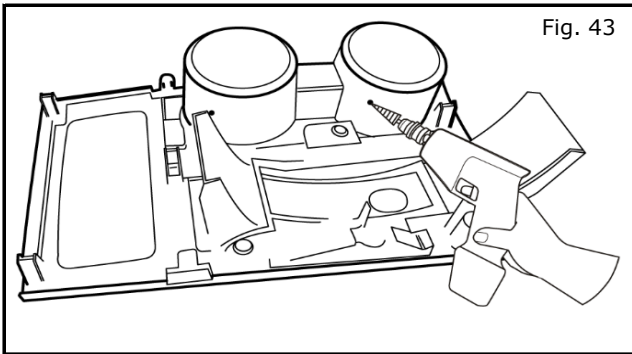

- 36) Drill hole for lamp lens opening.
- Drill 7/16" hole for each location. (Step Drill)
 - Inspect inner wall of cup holders for burr.
 - Carefully remove burr if necessary.

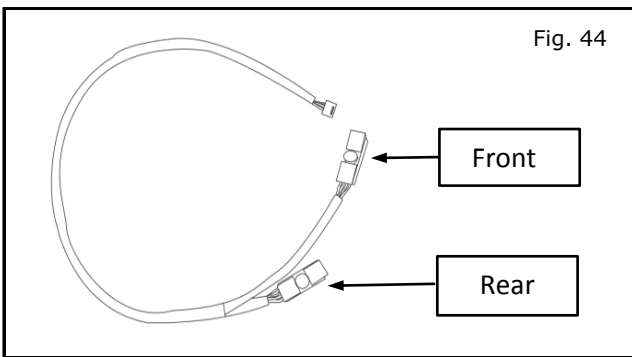

- 37) Prepare cup holder for LED lamp installation.
- Remove dust/debris from drilling steps.
 - Use Alcohol wipe to clean off area around hole.

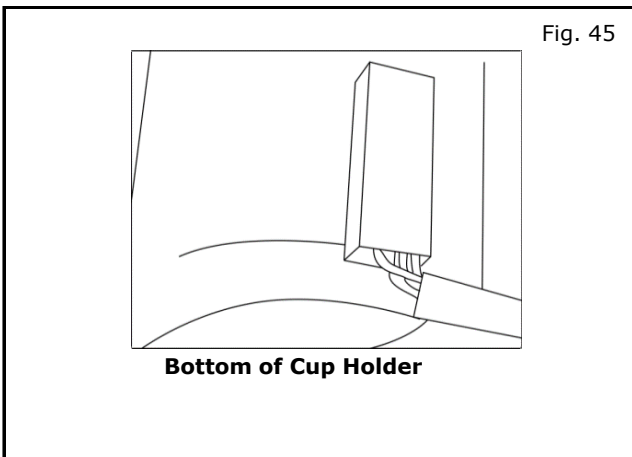

- 38) Cup holder lamp orientation.
- Peel adhesive tabs from front lamp.
 - Align lamp with cup holder, with harness exiting lamp toward bottom of cup holder.
 - Insert lamp lens in hole and contact adhesive pad to side of cup holder.
 - Inspect alignment and firmly press lamp against cup holder to bond.
- Repeat steps a) through d) for rear lamp.

INSTALLATION PROCEDURE:

Fig. 46

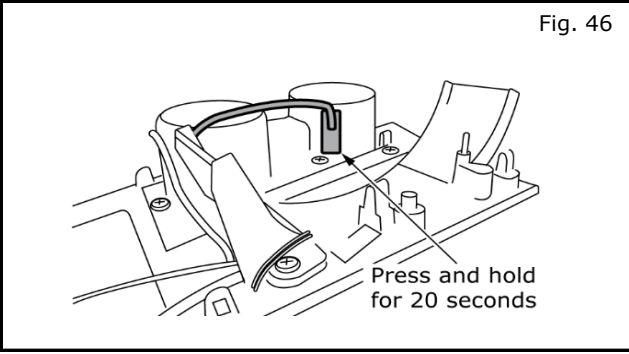

- 39) Installing cup holder lamps.
 - a) Press front lamp firmly and hold. Apply 15 lbs. pressure for 20 seconds.
 - b) Repeat for rear lamp.

Fig. 47

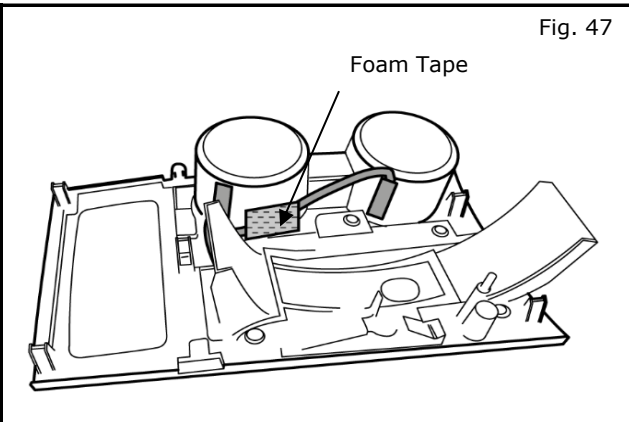

- 40) Route and secure cup holder lamp harness.
 - a) Apply foam tape to secure harness to console.
 - b) Route harness toward rear of finisher.

Fig. 48

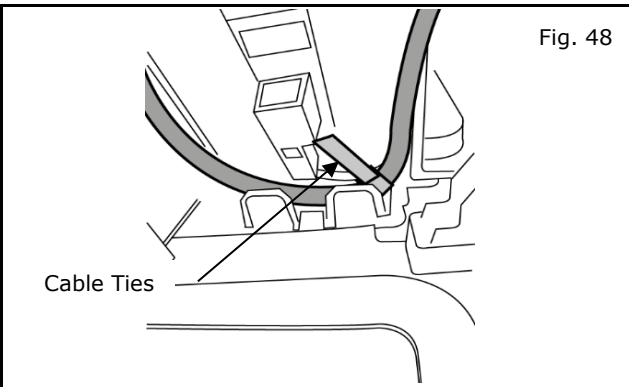

- c) Route harness along finisher harness and cable tie.

Fig. 49

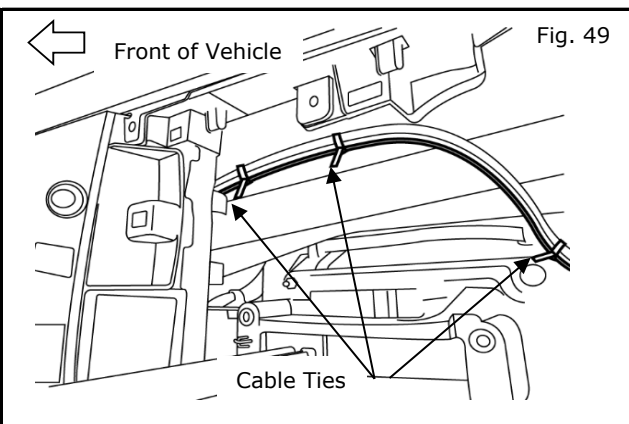

- d) Secure lamp harness using one wire tie (in addition to the two shown in Fig. 33) to center console as shown. Trim off excess wire tie as shown.

INSTALLATION PROCEDURE:

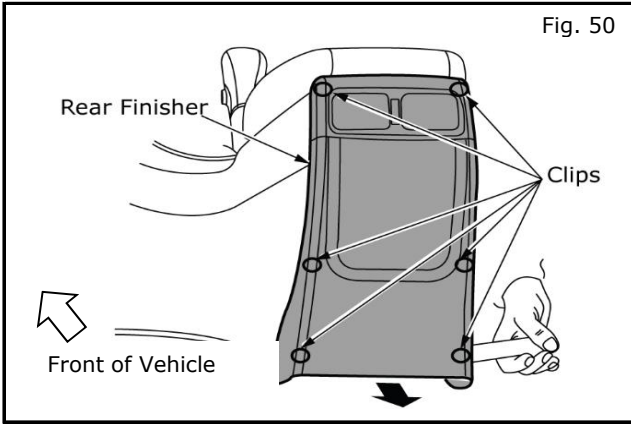

41) Remove rear console finisher using trim tool.

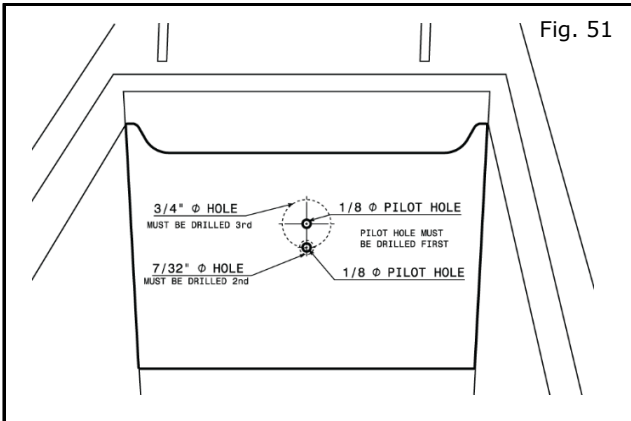

42) Light location and console storage bin preparation.

- Measure and mark two hole locations for console bin light with template provided in installation instructions.
- Template is used on inside back of bin.
- Holes are drilled from front to back.

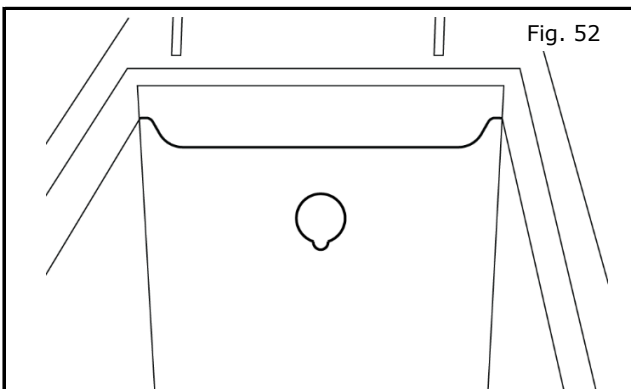

43) Drill two mounting holes for bin light.

- Drill two pilot holes using 1/8" drill bit that were marked.
- Drill 6 mm (7/32") hole using lower pilot hole
- Drill 19 mm (3/4") hole using upper pilot hole
- Remove burrs from holes.

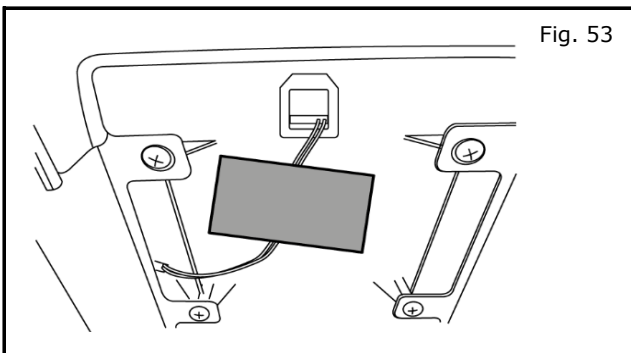

44) Install Bin Light Bezel from inside bin.

- Insert light from back into bezel as light as shown with harness pointing to driver's side (9 o'clock position) and turn down 1/4 turn to (6 o'clock position) lock light into bezel

INSTALLATION PROCEDURE:

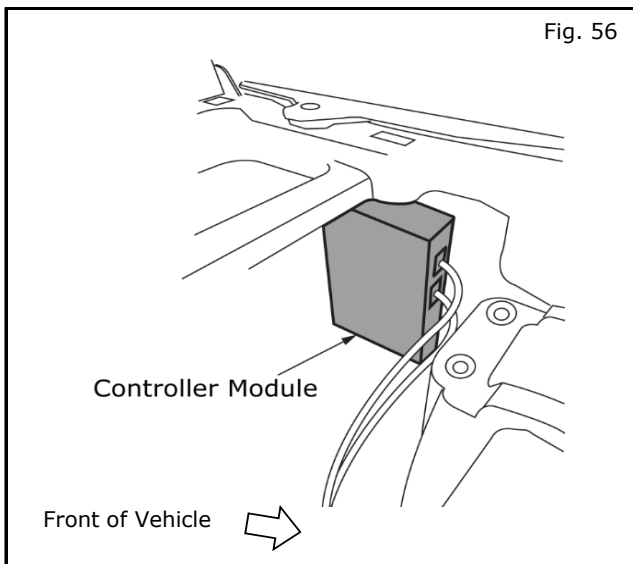
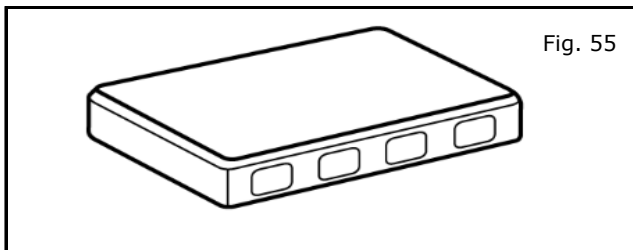
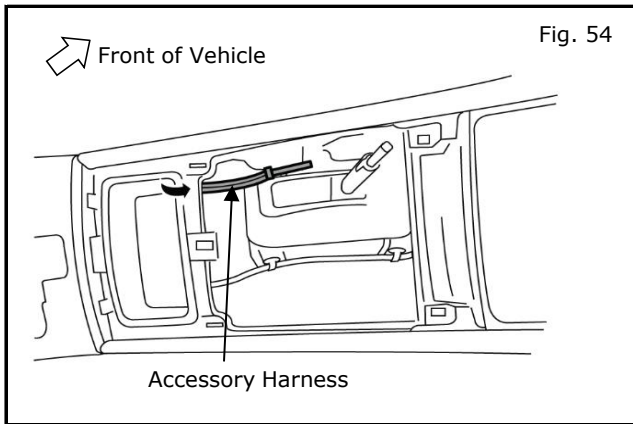

- 45) Routing bin light harness.
 - a) Tape bin light harness to 30" wire tie.
 - b) Fish 30" wire tie from back of vehicle towards front on left side of bin.
 - c) Disconnect 30" wire tie.
 - d) Connect bin light to ECU module.
 - e) Tape Bin Light Harness as shown in fig. 50.
 - f) Reinstall rear console finisher.

- 46) ECU connection port identification.
 - a) 5 pin OUT ports.
 - b) Plug footwell lamps into any 5 pin OUT port.
 - c) Plug cup holder lamps into any 5 pin OUT port.
 - d) Plug power harness into 7 pin VEHICLE port.
 - e) Plug switch into 4 pin **SWITCH** port.

- 47) Switch connection.
 - a) Route main harness to controller module.
 - b) Plug main harness into 7 pin VEHICLE port.
 - c) Press firmly, listen for "Click" and give a slight tug to check.
 - d) Route switch harness to controller module.
Plug switch harness into 4 pin OUT port.
 - e) Press firmly, listen for "Click" and give a slight tug to check.
 - f) Peel release liners off ECU adhesive tape.
 - g) Position ECU on left of center console as shown.
 - h) Firmly press module to console wall.
Press firmly and hold. Apply 15 lbs. pressure for 20 seconds.

INSTALLATION PROCEDURE:

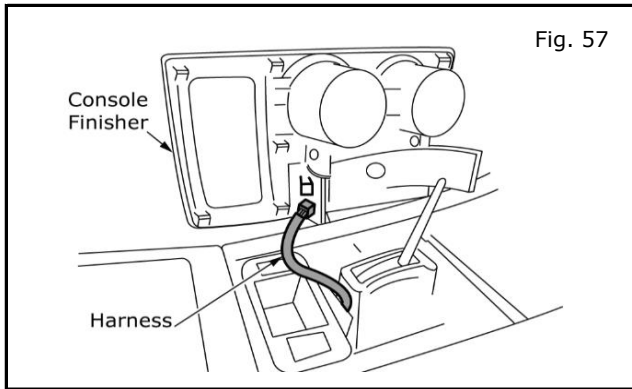

- 48) Reinstall console finisher panel.
- Check connections on finisher panel harness
 - Position finisher panel over console.
 - Align clips and lower into position.
 - Press down on finisher panel to engage clips.

NOTE:

- Conduct function check for ALL systems.
- Ensure Heater switch connectors are attached if present.

- 49) Reinstall gear selector knob.
- Check clip for proper installation on knob.
 - Place knob on lever and press down.
 - Pull boot up and secure retainer ring to base of shift knob.

ACCESSORY CHECK:

- Connect the battery negative terminal and tighten the nut to 5.4 N-m (47.8 lb-in)
- Check all **Critical Installation Steps**.
- Verify all wiring is secure and not exposed.
- Trim all excess cable ties flush.
- Turn ignition switch to "**ACC**" position.
- Confirm accessory main features and functions. Confirm cup holder, bin and food well lamps illuminate. Diagnostic flow chart is available on the next page for troubleshooting. (For complex electrical accessory, a diagnostic flow chart is required.)
- Check all vehicle electrical systems that the accessory interfaces with.
 - Vehicle electrical system 1 (Must for pre-wiring, overlay harness, and Posi-Tap)
 - Vehicle electrical system 2 (Electrical system(s) where the accessory connects.)

RE-INSTALLATION OF REMOVED PARTS:

- Re-install all removed vehicle parts. Refer to the vehicle service manual as necessary.

CAUTION

- Use caution when re-installing interior components to avoid damage, scratches, or breaking of mounting clips. Refer to the vehicle service manual for more information.

FINAL INSPECTION:

- Verify re-installed trim parts for proper flush fit (no gap, no waviness, etc.).
- Verify all clips are fully engaged and locked.
- Verify re-installed trim parts are free from cracks, scratches or stress marks.
- Verify vehicle headliner, seat, steering wheel, center console, floor carpets, etc. are not soiled.
- Verify interior and exterior is not damaged.
- Turn ignition switch to "ON" and confirm proper operation of Vehicle Systems
 - If equipped, verify all window and sunroof one touch operation and perform the reset procedure if necessary. Refer to the vehicle service manual for more details.
 - Confirm proper audio function (AM, FM, SAT, CD and AUX).

FINAL INSPECTION:

- Start engine and verify that there are no new Diagnostic Trouble Code. Turn ignition switch to "**OFF**".
- Place the Owner Manual, Quick Reference Guide, and/or other Manual in the glove box.
- If this vehicle will be returned to a dealer lot or showroom for an extended period of time, be sure the extended storage switch is placed in the "inventory" position. Refer to the Extended Storage Switch verbiage at the beginning of the 'INSTALLATION PROCEDURE' section.
- Re-program radio presets and other vehicle settings to the recorded settings. No need to do this step if the extended storage switch is placed in the "inventory" position.

INSTALLATION INSTRUCTIONS - Interior Accent Lighting Kit

CHECK OUT

- (1) Shut all doors on the vehicle.
- (2) Wait until all interior lamps go out.
- (3) Turn on **ACCESSORY**.
- (4) Verify that both Footwell Lights, Cupholder Lights, Bin Light and Switch light up and that switch changes light intensity.
- (5) Check the trim for a proper, flush fit after re-installing the interior components.
- (6) Clean the interior of the vehicle.
- (7) Inspect the vehicle interior and exterior for damage.
- (8) Check and clear trouble codes (DTC).
- (9) If this vehicle will be returned to a dealer lot or showroom for an extended period of time, be sure the extended storage switch is placed in the "inventory" position.
(Refer to section 9 - Vehicle Preparation)
- (10) If vehicle is NOT going into storage, reset the radio presets to the recorded settings.

Note: When diagnosing electrical system problems, first disconnect the accessory connectors and note effect on system. Continue the investigation with the accessory connectors disconnected. Remember to reconnect the accessories when the investigation is complete.

Posi-Tap™ is protected by patent # 5,228,875 5,695,369 5,868,589 6,692,313 Jap 2881414 Aus 708700 Tia 103534 Can 2204826 Mex 200626 Korea 477279 China Z197105562.9 & others pending.

INSTALLATION INSTRUCTIONS - Interior Accent Lighting Kit

BILL OF MATERIALS

Nissan Interior Accent Lighting Kit - 999F3 U4500

	Parts Contained in Bag Labelled 'Installation Kit'.	Qty	Part Number
1	Accent Lighting Controller (20 Color)	1	998F3 U4505
2	LED Light Pipe Assembly (w/Harness) DS / AS	1	998F3 U4501
3	Consul Bin Light- White (w/Harness)	1	998F3 U4502
4	Switch (w/Harness)	1	998F3 U4504
5	Cup Holder LED's (w/Harness)	1	998F3 U4506
6	Vehicle Interface Harness	1	999F3 4RA7A
7	Hardware Kit	1	998F3 U4503
8	Console Bin Light Bezel	1	999F3 U4507
9	Screw Phillips M5x16	2	0145 0015U
10	Clip Pushpin 8.0mm	2	01553 05933
11	Wire Tie 8in Black	10	
12	Carpet Tape	4	
13	Adhesive Back Foam	4	
14	Posi-Taps	5	99M1 VT000
15	Wire Tie, 30 inch	1	
16	Alcohol Wipes	3	
17	Vehicle Interface Harness	1	T99F3 4RA7A
18	Website Instructions w/Parts List	1	999V2 AW000
19	Quick Reference Guide	1	
20	Accessory Connector Harness (NOT INCLUDED IN KIT)	1	999Q9 AY000

ACCENT LIGHTING KIT

PASSENGER SIDE CONNECTOR

ACCY_SER_CONN

BAT	1
	2
ACC	3
	4
BAT_SAVER	5
DOOR_SW	6
THRU_SIGNAL_1	7
THRU_SIGNAL_2	8
	9
ROOM_LAMP	10
	11
GND	12

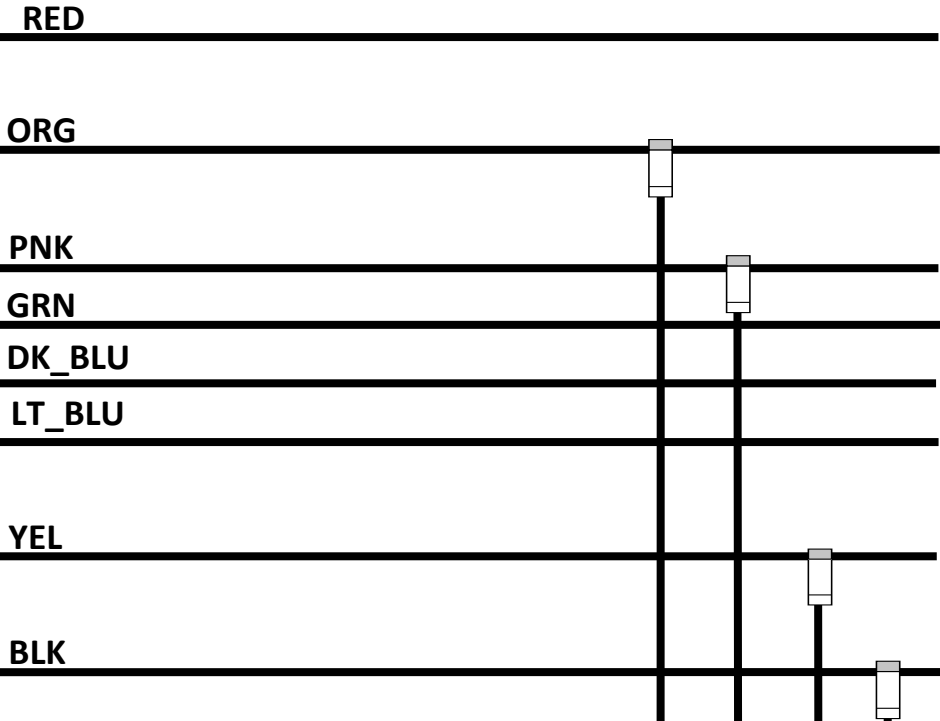

Note: Pin location is referenced looking into wire side of connector.

TH12FW-NH

1	2	3	4	5	6
7	8	9	10	11	12

Switch (Color)

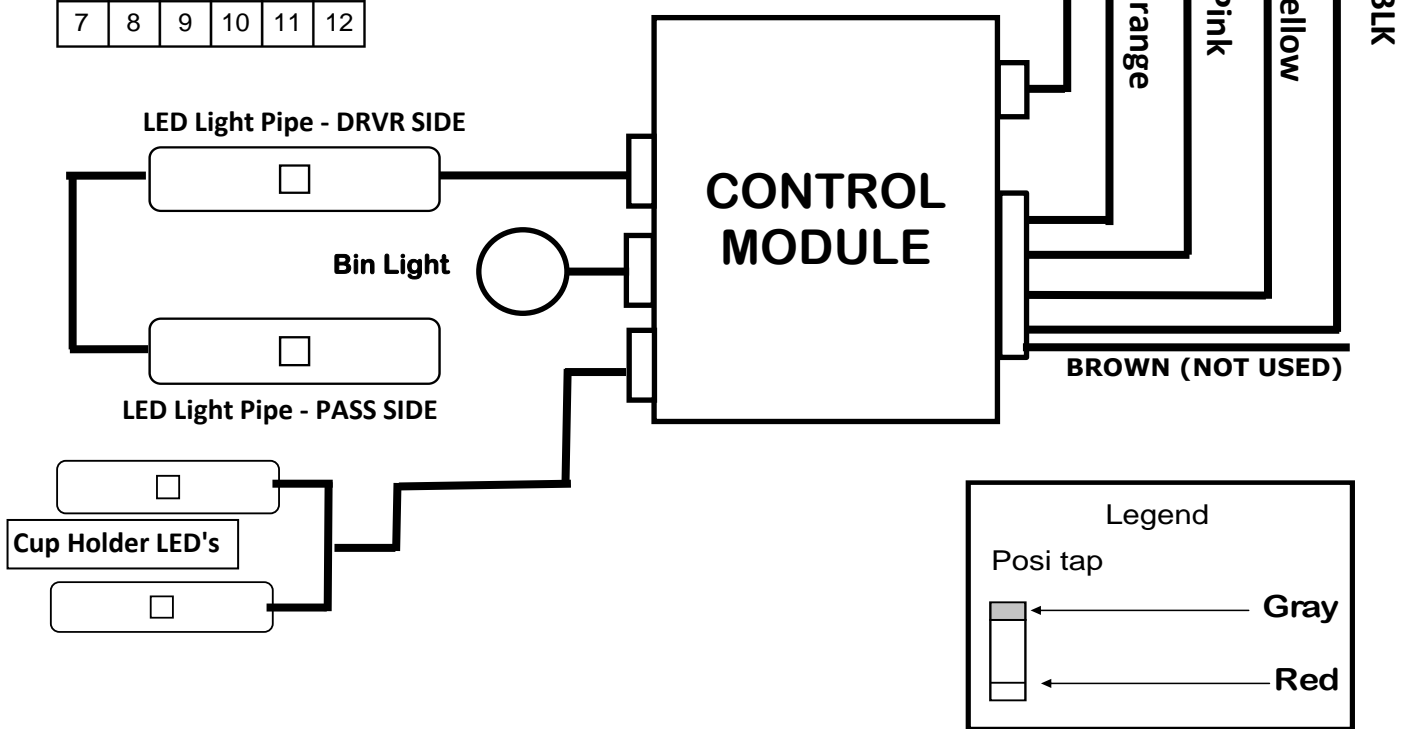
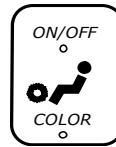

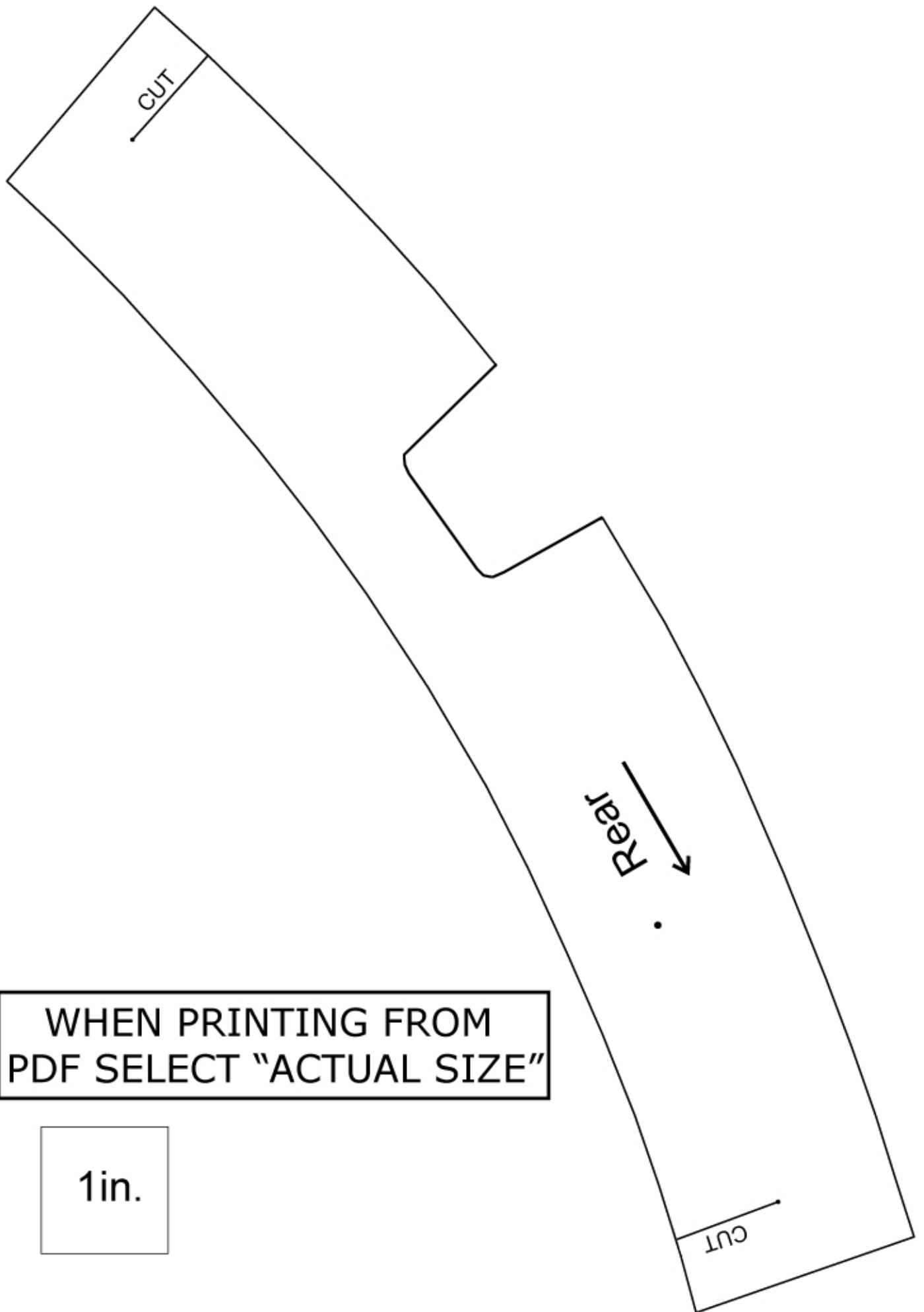

WHEN PRINTING FROM
PDF SELECT "ACTUAL SIZE"

1in.

WHEN PRINTING FROM PDF
SELECT "ACTUAL SIZE"

1in.

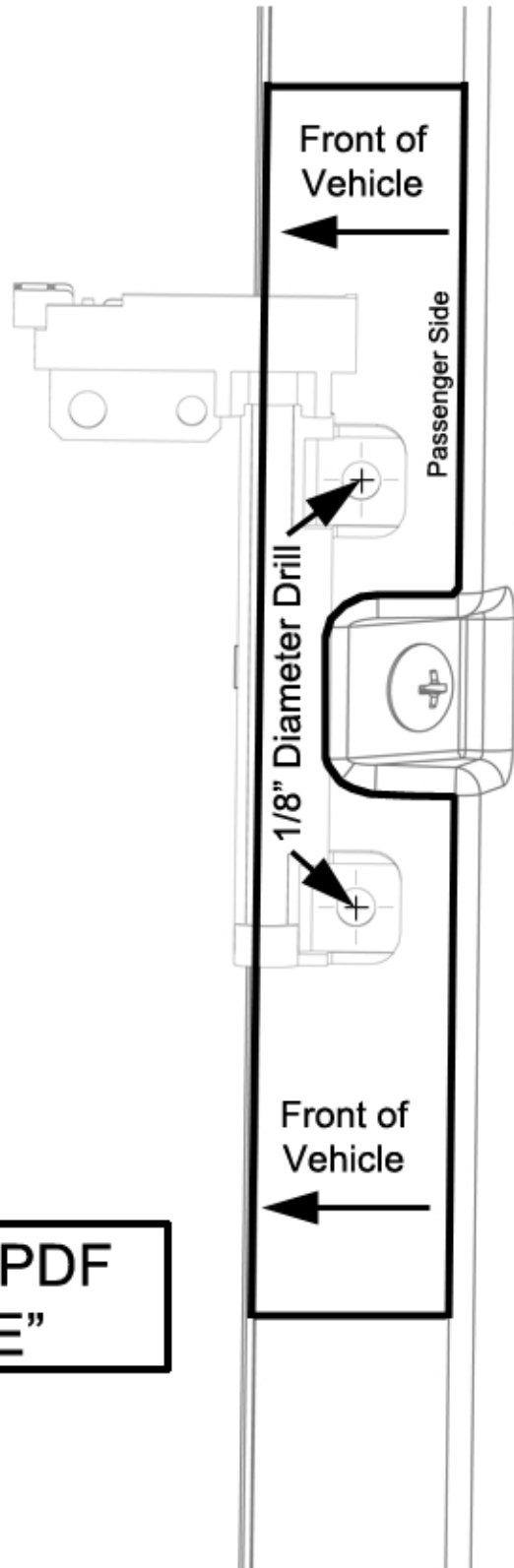

SWITCH INSTALLATION TEMPLATES

DRILLING TEMPLATE

1. CUT OUT SOLID LINES FOR DRILLING TEMPLATE. LINE UP TEMPLATE AS SHOWN AN DRILL HOLE WHERE MARKED.

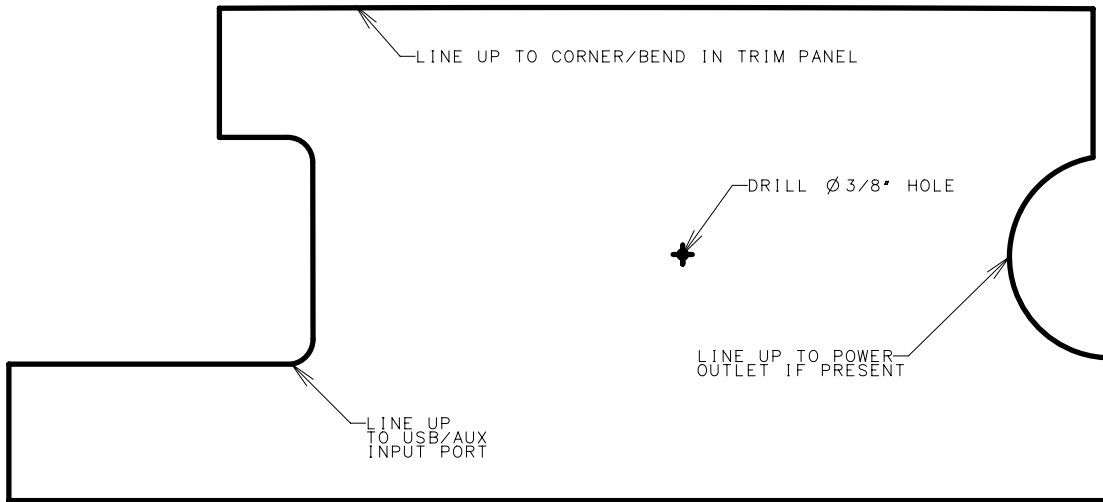

ALIGNMENT TEMPLATE

2. CUT OUT SOLID AND DASHED LINES FOR ALIGNMENT TEMPLATE. LINE UP TEMPLATE AS SHOWN, REMOVE ADHESIVE BACKING FROM SWITCH, PLACE SWITCH AS SHOWN, USING THE TOP, LEFT AND RIGHT EDGES AND GUIDES.

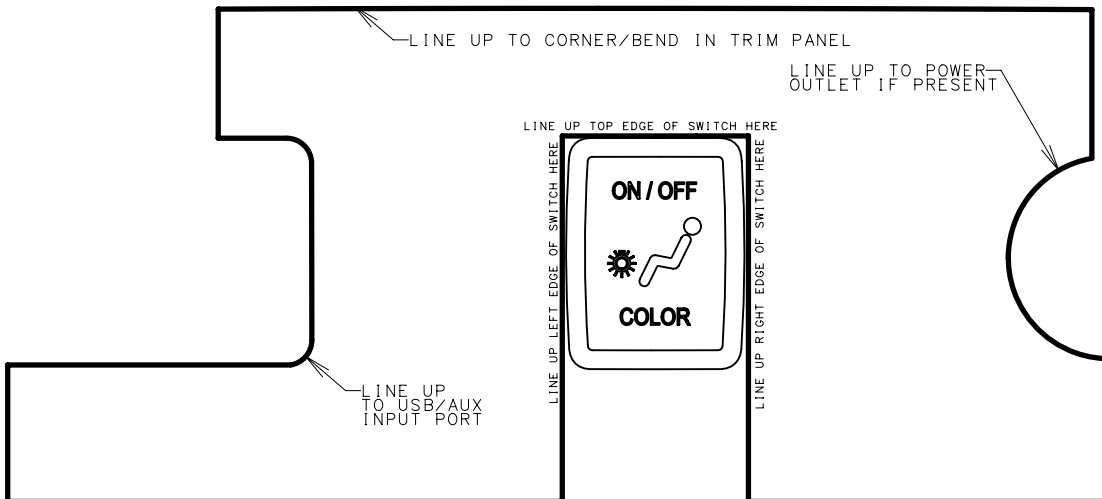

WHEN PRINTING FROM PDF SELECT "ACTUAL SIZE"

1 in.

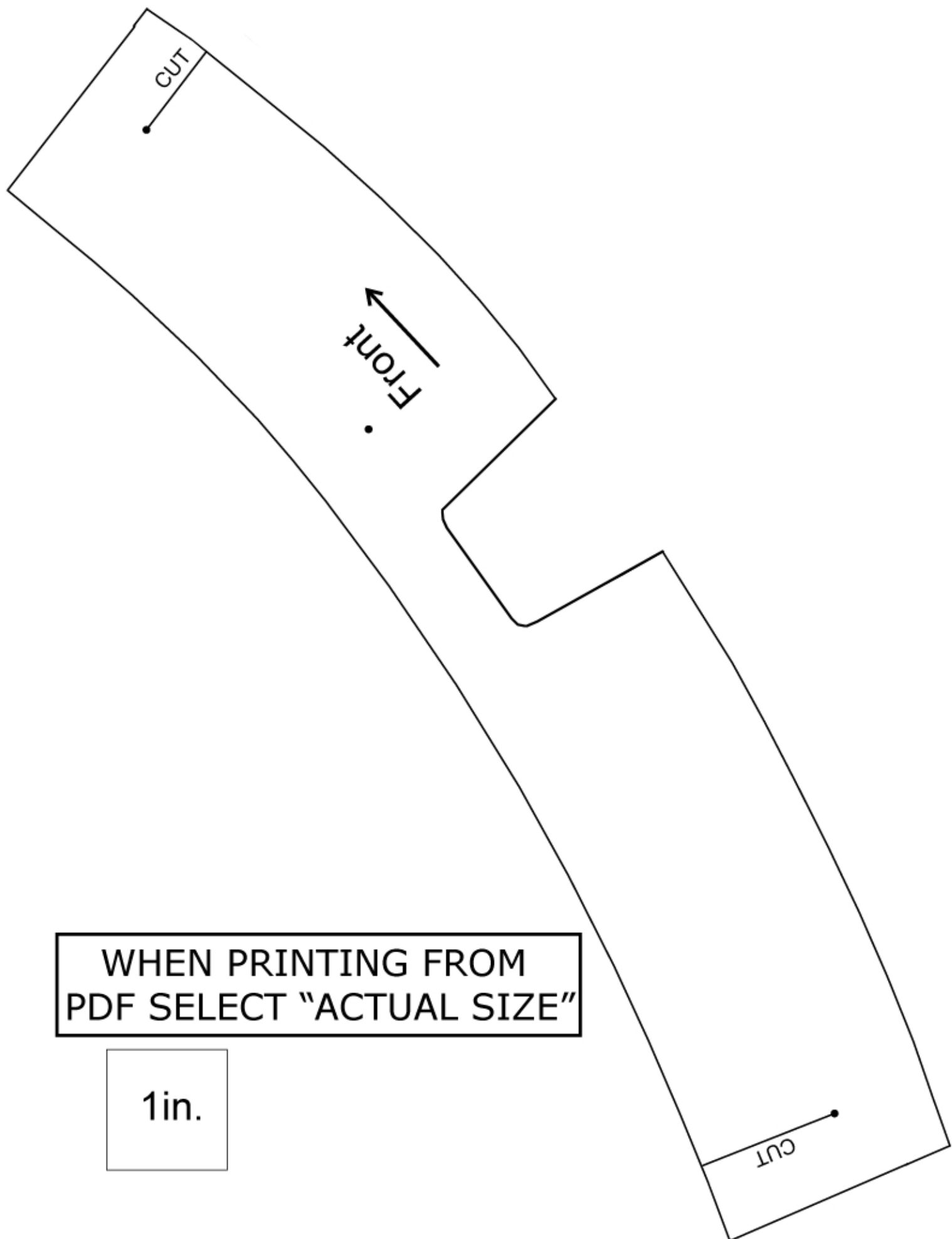

WHEN PRINTING FROM
PDF SELECT "ACTUAL SIZE"

1in.

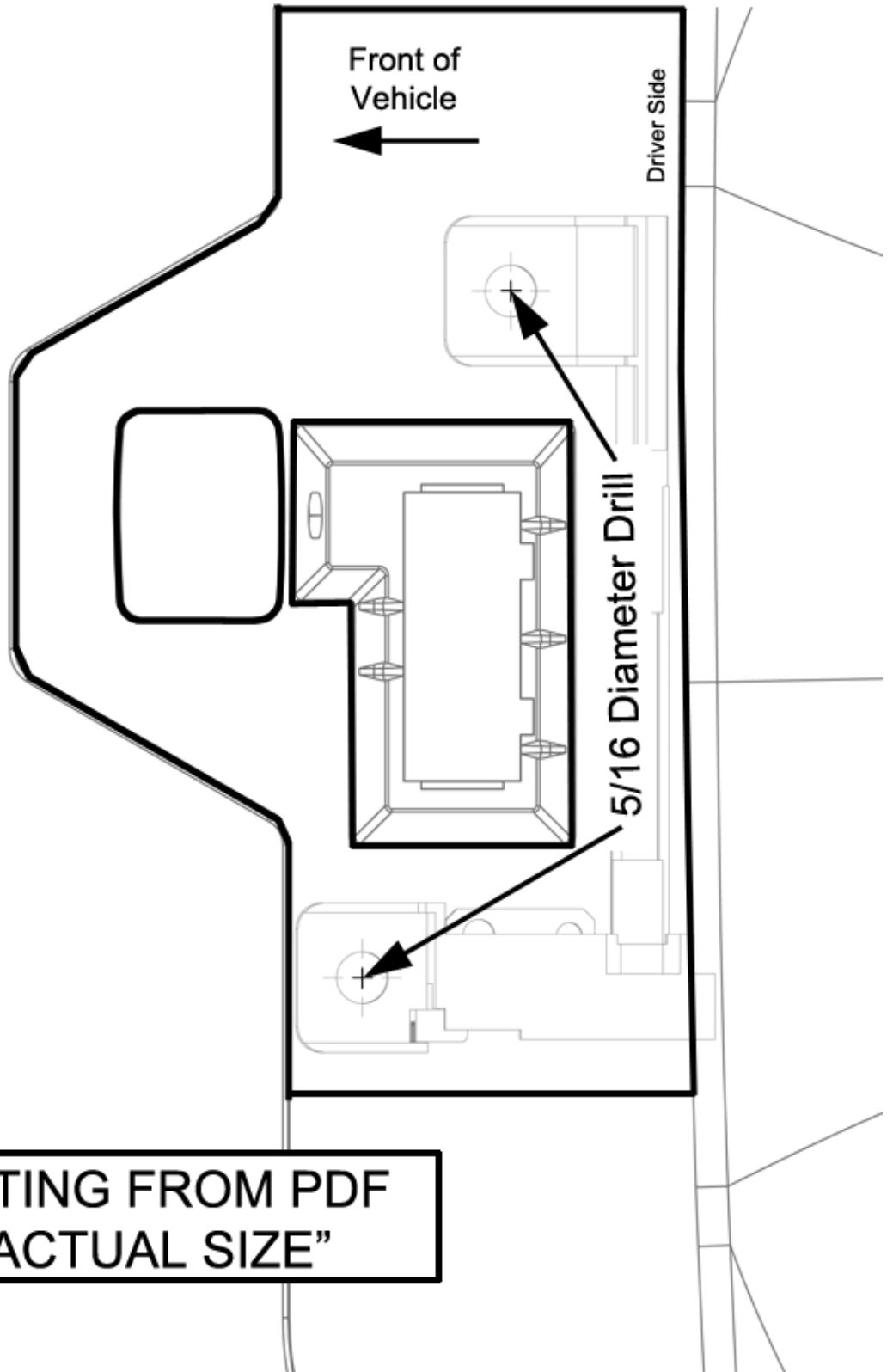

WHEN PRINTING FROM PDF
SELECT "ACTUAL SIZE"

1in.

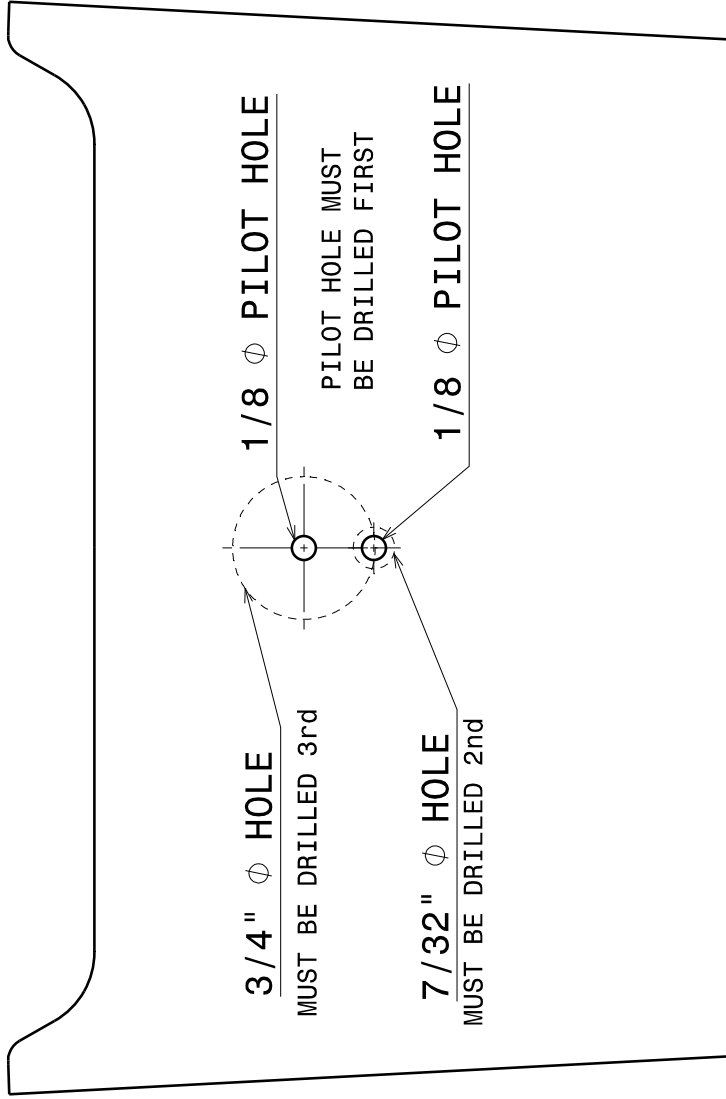

THIS TEMPLATE MUST BE PRINTED AT ITS ACTUAL SIZE

1 INCH
SQUARE